

DESIGN FEATURES

- Built-in ISO 5211 Direct Mounting Pad Easy Automation
- Anti-static Devices for Ball-Stem-Body
- Blow-out Proof Stem
- Pressure Balance Hole in Ball Slot
- TA-Luft/ ISO 15848-1 Design Approved
- NACE standard MR0175 & MR0103 (Optional)
- Casting Approved by TUV AD 2000-Merkblatt W0
- Options : 1.Actuator 2.Limit Switch 3.Positioner



APPLICABLE STANDARDS

- Design Standard : MSS SP-110
- Wall Thickness : EN12516-3,
- Pipe Thread : ASME B1.20.1,BS21, EN 10226
 DIN 2999/259, ISO 228/1
 JIS B0203 ISO7/1
- Inspection & Testing : MSS SP-110

CV VALUES

NPS	DN	CV
1/4	8	16
3/8	10	23
1/2	15	30
3/4	20	55
1	25	96
1 1/4	32	170
1 1/2	40	270
2	50	470
2 1/2	65	780
3	80	1150

WEIGHT

NPS	DN	Weight	
		(kg)	(lb)
1/4	8	0.58	1.28
3/8	10	0.55	1.21
1/2	15	0.51	1.12
3/4	20	0.61	1.34
1	25	1.10	2.43
1 1/4	32	1.42	3.13
1 1/2	40	2.04	4.50
2	50	3.27	7.21
2 1/2	65	6.04	13.3
3	80	9.17	20.2

TORQUE VALUES

Close to Open Torque at Various Differential Pressure (ΔP), Standard Seats (TFM1600 & PTFE)

unit : in-lb / N-m

Size/ ΔP		75 psig		150 psig		300 psig		700 psig		1000 psig	
		5 bar		10 bar		20 bar		50bar		63bar	
NPS	DN	N-m	In-lb	N-m	In-lb	N-m	In-lb	N-m	In-lb	N-m	In-lb
1/4	8	4.5	40	4.5	40	4.5	40	4.5	40	4.5	40
3/8	10	4.5	40	4.5	40	4.5	40	4.5	40	4.5	40
1/2	15	5	44	5	44	5	44	5	44	5	44
3/4	20	6	53	6	53	6	53	6	53	6	53
1	25	10	88	10	89	11	97	11	97	11	97
1 1/4	32	13	115	13	115	15	133	17	150	19	168
1 1/2	40	19	168	19	168	22	195	24	212	26	230
2	50	25	221	29	257	32	283	35	310	38	336
2 1/2	65	40	354	45	398	49	434	54	478	59	522
3	80	65	575	72	637	81	717	90	796	101	894

- Remark :
- Torques will increase about 30% if seat materials are Reinforced Fiber-Glass PTFE, Carbon-filled PTFE or EK+PTFE or TFM4215.
 - The torque figures at 5 bar pressure are maximum values to be tested after the valves are placed for 24 hours.
 - For actuator sizing, a safety factor of minimum 30% is recommended.

TECHNICAL INFORMATION

PRESSURE - TEMPERATURE DATA

The pressure-temperature data of ball valves are determined not only by valve shell materials but also by sealing materials used for ball seats, gland packings and flange gaskets.

Full Bore : NPS 1/2 ~ NPS 1 1/4
DN15 to DN32

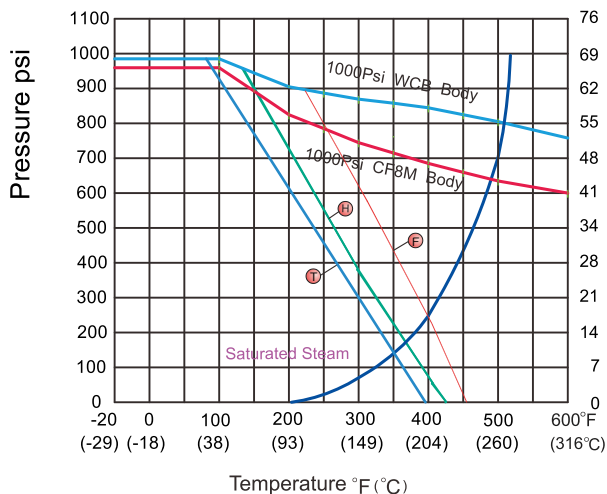

Full Bore : NPS 1 1/2 ~ NPS 3
DN40 to DN80

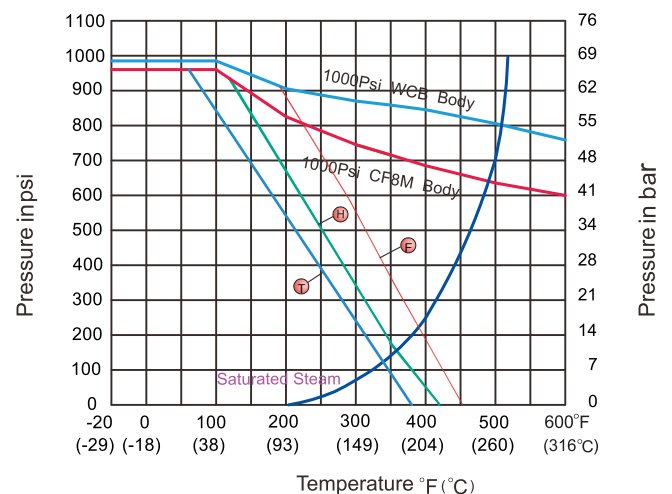

Seat Materials : (T) PTFE (H) TFM1600 (E) TFM4215

Body Ratings: Shown above are for ASTM A351 Gr.CF8M and A216 Gr.WCB

For ratings of other valve shell materials, please refer to the last edition of ASME B16.34.

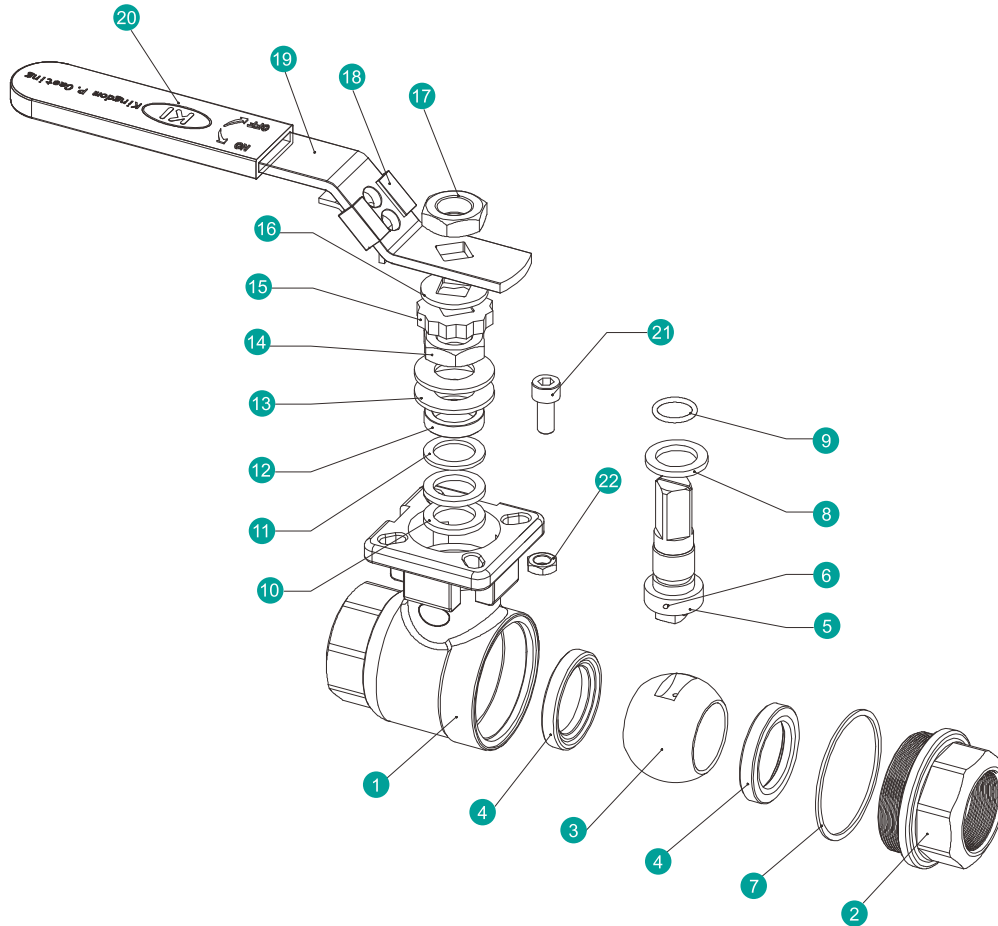

MATERIAL OF CONSTRUCTION

NO.	PART NAME	MATERIALS		
1	Body	CF8M(1.4408)	CF8(1.4308)	WCB(1.0619)
2	End Cap	CF8M(1.4408)	CF8(1.4308)	WCB(1.0619)
3	Ball	316	304	
4	Ball Seat	TFM1600 /PTFE/TFM4215		
5	Stem	316	304	
6	Anti-Static	316	304	
7	Body Gasket	PTFE/TFM1600 / GRAPHITE*		
8	Thrust washer	PTFE/TFM1600/ RTFE		
9	O-Ring	FKM		
10	Packing	PTFE / GRAPHITE*		
11	Bushing	50%SS+50%PTFE / 304		
12	Gland	316		
13	Belleville Washer	301		
14	Stem Nut	A194-8		
15	Stop-lock-Cap	304		
16	Handle Gland	304		
17	Handle Nut	A194-8		
18	Lock Device	304		
19	Handle	304		
20	Handle Sleeve	VINYL PLASTIC		
21	Stop Bolt	A2-70		
22	Stop Nut	A2-70		

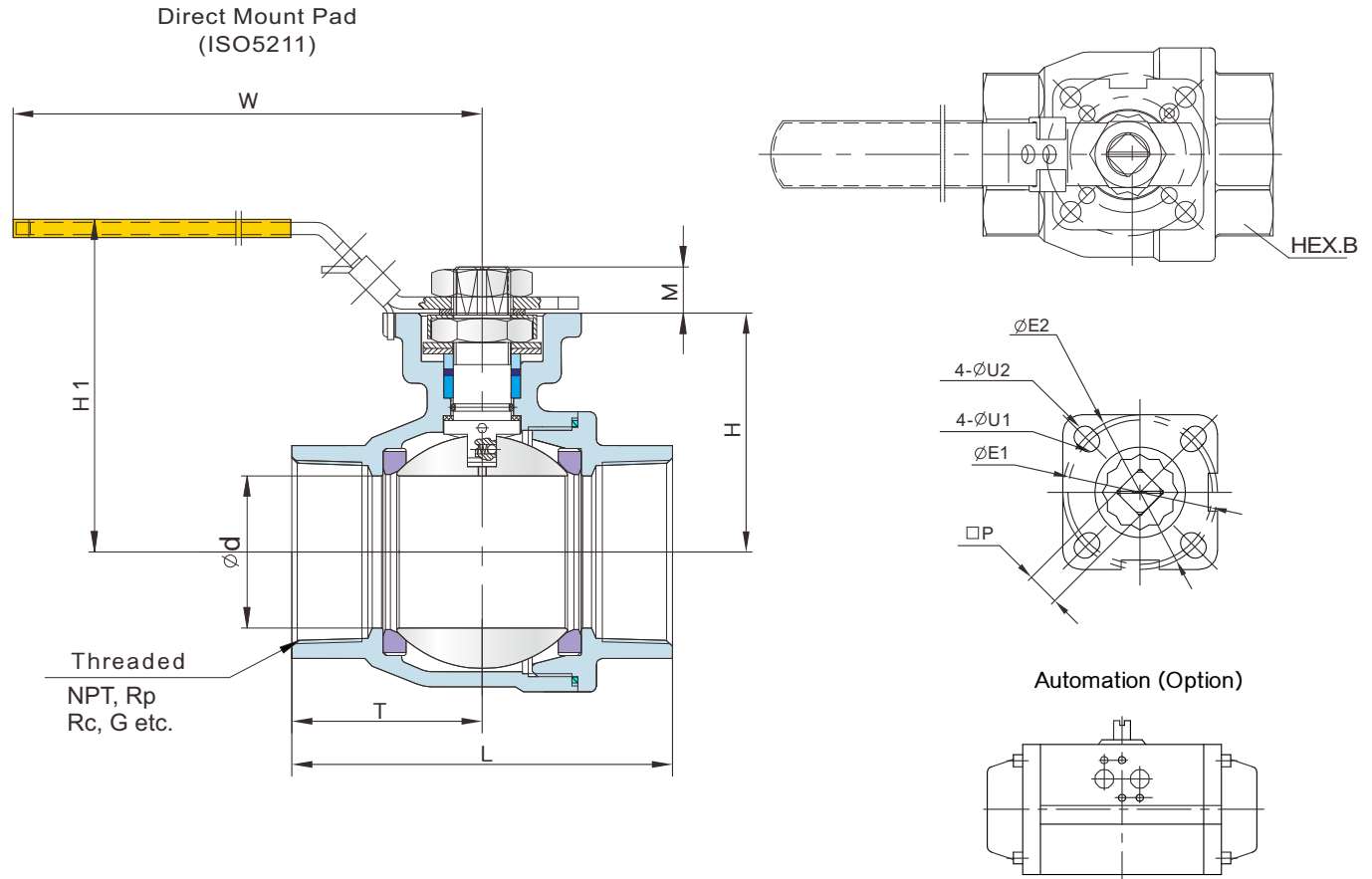

DIMENSION TABLE

ANSI 1000 WOG DIMENSION TABLE

Unit : mm

NPS	DN	d	L	W	H	H1	T	P	M	E1	E2	U1	U2	HEX.B	ISO 5211
1/4	8	10.6	67	147	42.5	73	33.5	9	9	36	42	6	6	27	F03-F04
3/8	10	12.7	67	147	42.5	73	33.5	9	9	36	42	6	6	27	F03-F04
1/2	15	15	67	147	42.5	73	33.5	9	9	36	42	6	6	27	F03-F04
3/4	20	20	70.4	147	49	79	35.2	9	9	36	50	6	7	32	F03-F05
1	25	25	85	177	58	88	42.5	11	11	42	50	6	7	41	F04-F05
1 1/4	32	32	94	177	62.5	93	47	11	11	42	70	6	9	50	F04-F07
1 1/2	40	38	105	197	71.5	103	52.5	14	14	50	70	7	9	56	F05-F07
2	50	50	125	197	78.5	110	62.5	14	14	50	70	7	9	70	F05-F07
2 1/2	65	63.5	155	267	100	150	77.5	17	17	70	102	9	11	83	F07-F10
3	80	76	173	267	109	159	86.5	17	17	70	102	9	11	102	F07-F10

Unit : inch

NPS	DN	d	L	W	H	H1	T	P	M	E1	E2	U1	U2	HEX.B	ISO 5211
1/4	8	0.42	2.64	5.79	1.67	2.87	1.32	0.354	0.35	1.42	1.65	0.24	0.24	1.06	F03-F04
3/8	10	0.50	2.64	5.79	1.67	2.87	1.32	0.354	0.35	1.42	1.65	0.24	0.24	1.06	F03-F04
1/2	15	0.59	2.64	5.79	1.67	2.87	1.32	0.354	0.35	1.42	1.65	0.24	0.24	1.06	F03-F04
3/4	20	0.79	2.77	5.79	1.93	3.11	1.39	0.354	0.35	1.42	1.97	0.24	0.28	1.26	F03-F05
1	25	0.98	3.35	6.97	2.28	3.46	1.67	0.433	0.43	1.65	1.97	0.24	0.28	1.61	F04-F05
1 1/4	32	1.26	3.70	6.97	2.46	3.66	1.85	0.433	0.43	1.65	2.76	0.24	0.35	1.97	F04-F07
1 1/2	40	1.50	4.13	7.76	2.81	4.06	2.07	0.551	0.55	1.97	2.76	0.28	0.35	2.20	F05-F07
2	50	1.97	4.92	7.76	3.09	4.33	2.46	0.551	0.55	1.97	2.76	0.28	0.35	2.76	F05-F07
2 1/2	65	2.50	6.10	10.5	3.98	5.91	3.05	0.669	0.67	2.76	4.02	0.35	0.43	3.27	F07-F10
3	80	2.99	6.81	10.5	4.29	6.26	3.41	0.669	0.67	2.76	4.02	0.35	0.43	4.02	F07-F10